

PASLANMAZ ÇELİK
BORU UCLU / MANUEL KUMANDALI
TANK İÇİNE AÇILAN TİP DİP VANASI

SERİ : 604

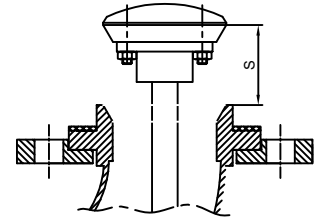
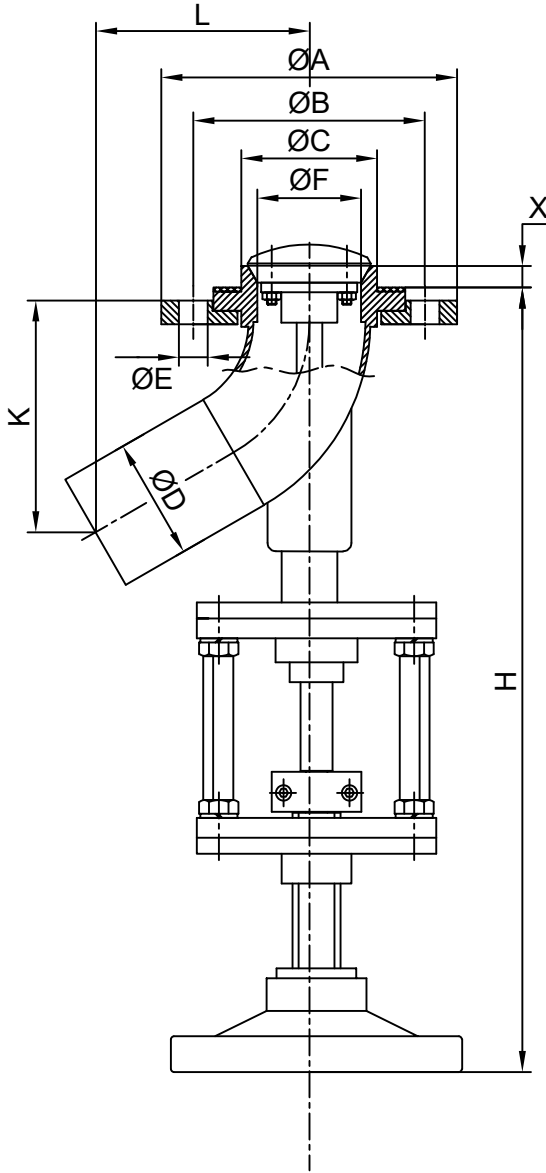

Strok pozisyonu

Çalışma basıncı : Maksimum 16 bar
 Çalışma sıcaklığı : -10°C / 220°C

BOYUT		ØA	ØB	ØC	ØD	ØE	Delik Sayısı	H	K	L	X	S
25	1"	115	85	50	33.7	14	4	320	95	88	16	30
32	1 1/4"	140	100	57	42.4	18	4	334	114	110	16	30
40	1 1/2"	150	110	60	48.3	18	4	344	123	115	16	30
50	2"	165	125	75	60.3	18	4	363	135	125	16	30
65	2 1/2"	185	145	85	76.1	18	4	426	157	135	17	40
80	3"	200	160	102	88.9	18	8	450	173	145	17	40
100	4"	220	180	122	114.3	18	8	487	207	165	18	40
125	5"	250	210	152	139.7	18	8	530	227	180	20	40
150	6"	285	240	177	168.3	22	8	570	260	200	20	40

NOT : İstek halinde "X" yüksekliği farklı ölçüde yapılabilir.



ALFANOX

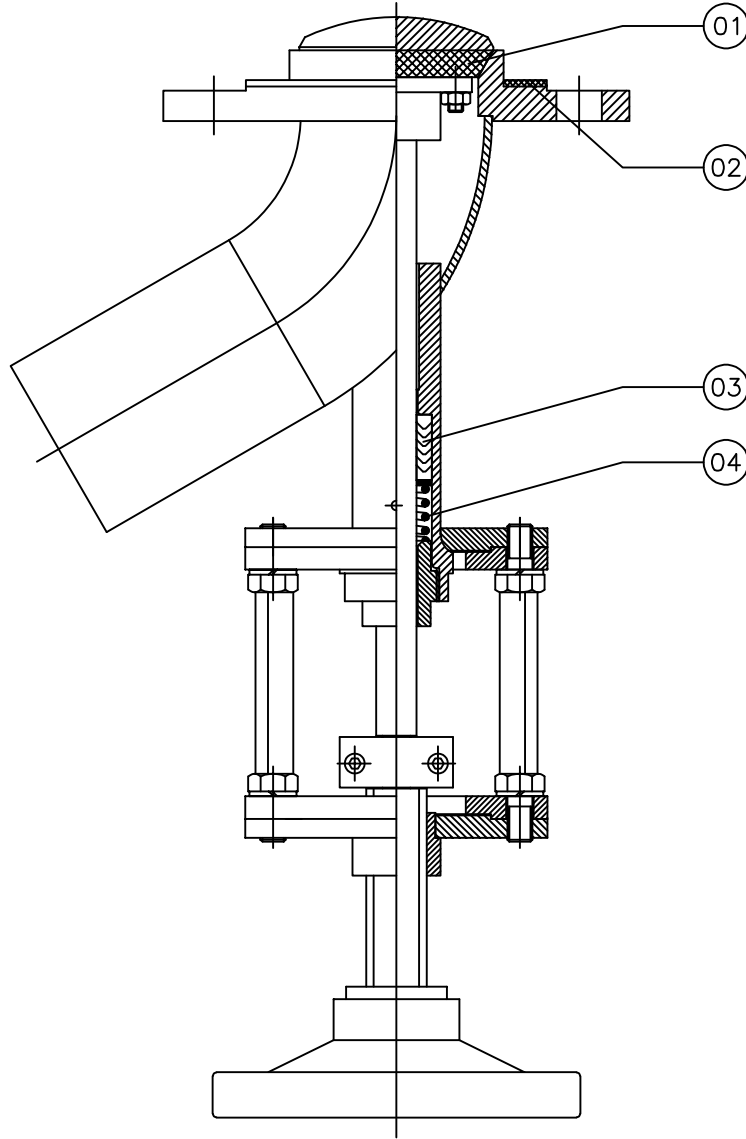

Yedek parça siparişleriniz için aşağıdaki çizelgeden seçtiğiniz parça no'suyla birlikte vananızın üzerinde yazılı olan seri no'sunu bildirmeniz yeterlidir.

YEDEK PARÇA LİSTESİ		
PARÇA NO	PARÇA ADI	MALZEME
01	KAPATMA ELEMANI	PTFE
02	ÜST FLANŞ CONTASI	PTFE
03	SALMASTRA PAKETİ	PTFE
04	SALMASTRA YAYI	INOX

